

XCHANGE

BUSINESS PARK AT MOUNT LEHMAN

BRAND NEW INDUSTRIAL SPACE FOR LEASE



MOUNT LEHMAN WAY
ABBOTSFORD, BC



LOCATION

The Lower Mainland's Most Convenient Industrial Hub

Anchored in the heart of the Lower Mainland, Abbotsford is a vibrant city with a thriving economy and bustling industrial lands less than an hour's drive from Vancouver's downtown core.

With its university, regionally-serving business, hospital, diverse employment base, airport, and half of the region's population, it's no surprise Abbotsford has become a major hub of activity and a catalyst for eastward migration from Vancouver.

The largest city by area in British Columbia, Abbotsford is only 20 minutes away from two major US border crossings and has direct access to the Province's primary transit corridor, Highway 1.

Abbotsford has the most diverse economy among mid-sized cities in Canada, with industrial labour comprising 30% of the City's total labour force. As the primary employment, business centre, and industrial hub of the Fraser Valley, and fast and efficient access to Vancouver, Abbotsford is a highly desirable location to invest in.



Neighbourhood Amenities

- Offers a wide variety of state-of-the-art services from the iconic Highstreet Shopping Centre to the Fraser Valley Automall.
- An assortment of nearby employee amenities that include: Famoso Pizza, Starbucks, McDonald's, Freshi, Tim Horton's, Mucho Burrito, Subway, Canadian Brewhouse, Milestone's Bar & Grill, Broddeur's Bistro, Panago Pizza, Quiznos, and several others.
- 12-minute drive to Abbotsford's Historic Downtown.
- Access to local rapid transit system via BC Transit.
- Minutes away from 3 city parks with dedicated pathways for walking and cycling.
- World-class festivals and events like the Abbotsford International Air Show, and the Abbotsford Agrifair.

Superior Accessibility

- Located at 3707 Mount Lehman Road in Abbotsford, a quick 2-minute drive to the Highway 1 interchange at Mount Lehman Road.
- Direct US border access via Sumas Crossing, Aldergrove Crossing, and Peace Arch Crossing.
- 6-minutes from Abbotsford International Airport.
- Approximately 1-hour from Vancouver International Airport.
- Direct connection to the South Fraser Perimeter Road, creating seamless access to the Port of Vancouver's Deltaport Facility.

SITE PLAN

Xchange Business Park is a 140-acre industrial district conveniently located at Mount Lehman Road and Highway 1 Interchange. The property features modern, state-of-the-art, Class A industrial space for lease.

Building sizes range from 49,000 SF to 195,000 SF including build-to-suit opportunities, this new master plan industrial business park is ideal for logistics and warehouse users. Xchange offers a number of industry-leading specifications including 32'+ clear ceiling height, 55' column spacing, dock and grade-level doors, LED to 30-foot candle lighting, ESFR sprinklers, and more.



PHASE 1

BUILDING DETAILS

BUILDING 2

30315 Blueridge Drive
FOR LEASE

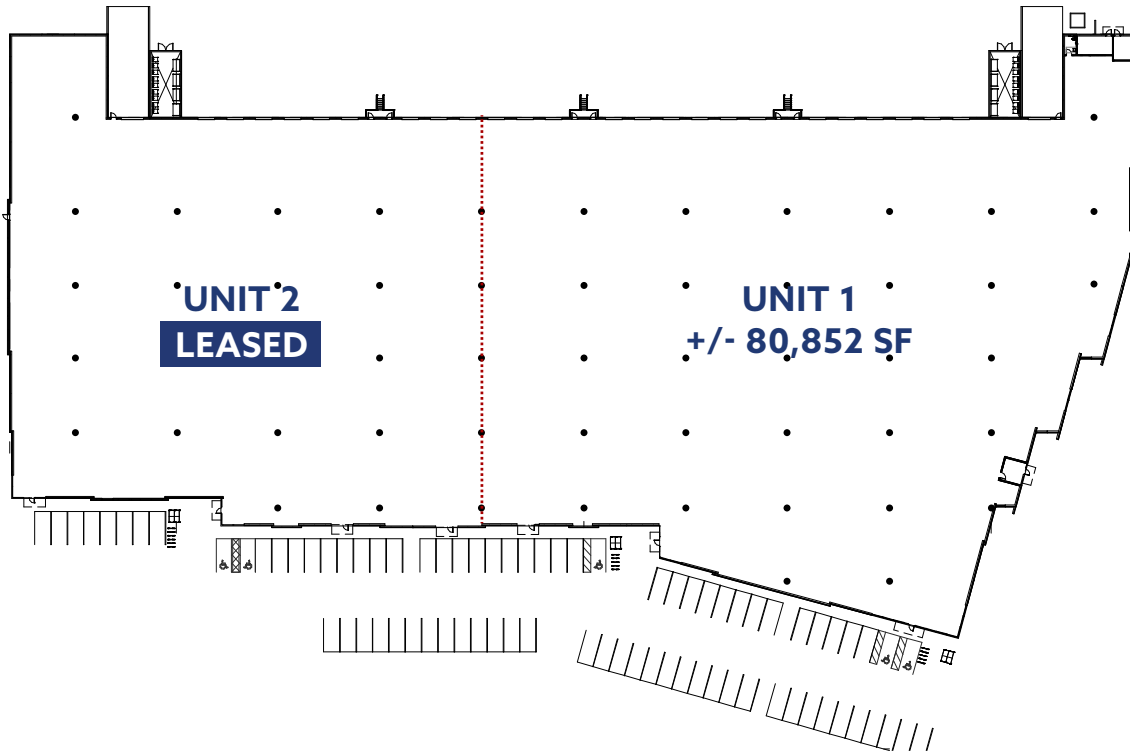
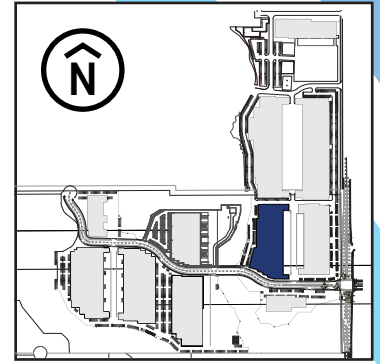

Building Size	+/- 137,850 square feet of ground floor area	Sprinkler System	ESFR sprinklers
Zoning	I-2	Column Grid	Typical 55'x40' column spacing
Ceiling Height	32' clear ceiling height	Power	Maximum connected power 2,000 kva
Loading Doors	24 dock level doors with levellers 2 grade level doors	Heating	Gas fired unit heaters and fans
Floor Load	750 lbs. psf (live load)	Parking Stalls	+/- 80 stalls
Warehouse Lighting	LED to 30 foot candle		

BUILDING 4

30215 Blueridge Drive
FOR LEASE

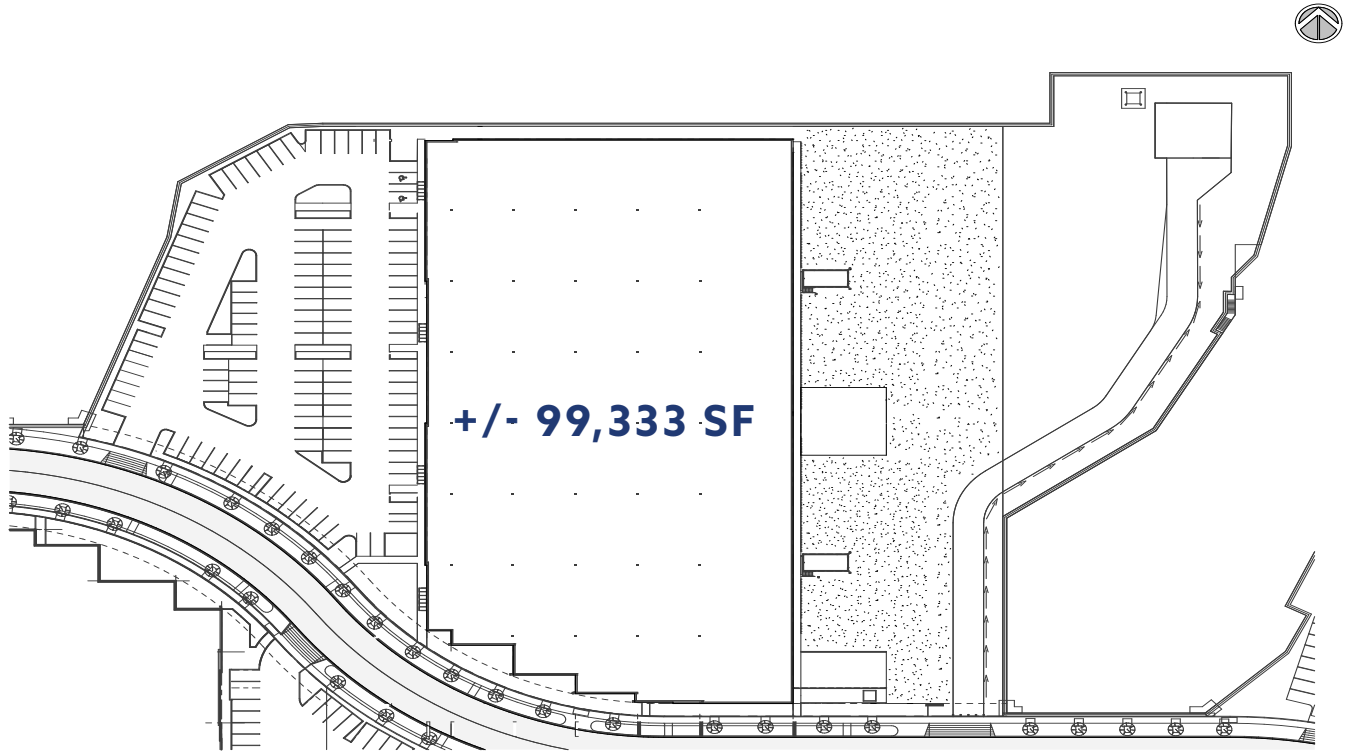
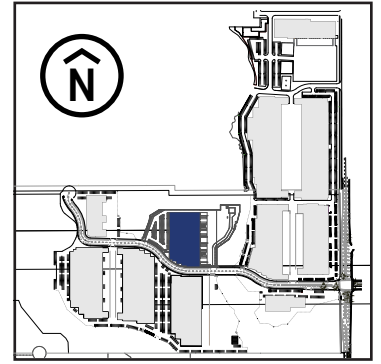

Building Size	+/- 99,333 SF	Warehouse Lighting	LED to 30 foot candle
Zoning	I-2	Sprinkler System	ESFR sprinklers
Ceiling Height	32' clear ceiling height to structure	Column Grid	Typical 55' x 40' column spacing
Loading Doors	14 dock level doors with levellers 4 grade level doors	Power	Maximum connected power 1,600 kva
Floor Load	500 lbs. psf (live load)	Heating	Gas fired unit heaters and fans

BUILDING 5

30220 Blueridge Drive
FOR LEASE

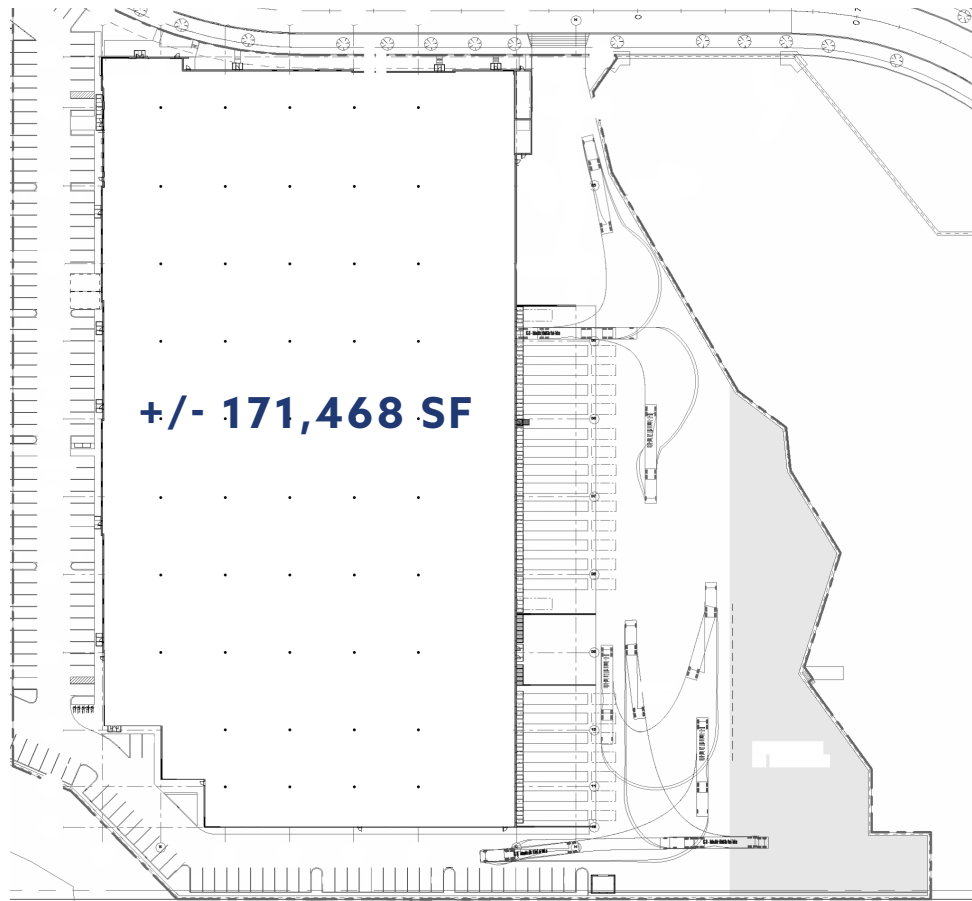
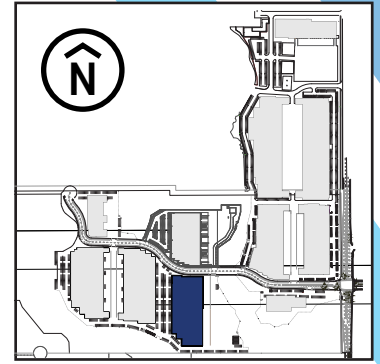

Building Size	+/- 171,468 SF	Warehouse Lighting	LED to 30 foot candle
Zoning	I-2	Sprinkler System	ESFR sprinklers
Ceiling Height	36' clear ceiling height to structure	Column Grid	Typical 55' x 40' column spacing
Loading Doors	21 dock level doors with levellers 2 grade level doors	Power	Maximum connected power 1,600 kva
Floor Load	500 lbs. psf (live load)	Heating	Gas fired unit heaters and fans

BUILDING 6

30160 Blueridge Drive
FOR LEASE

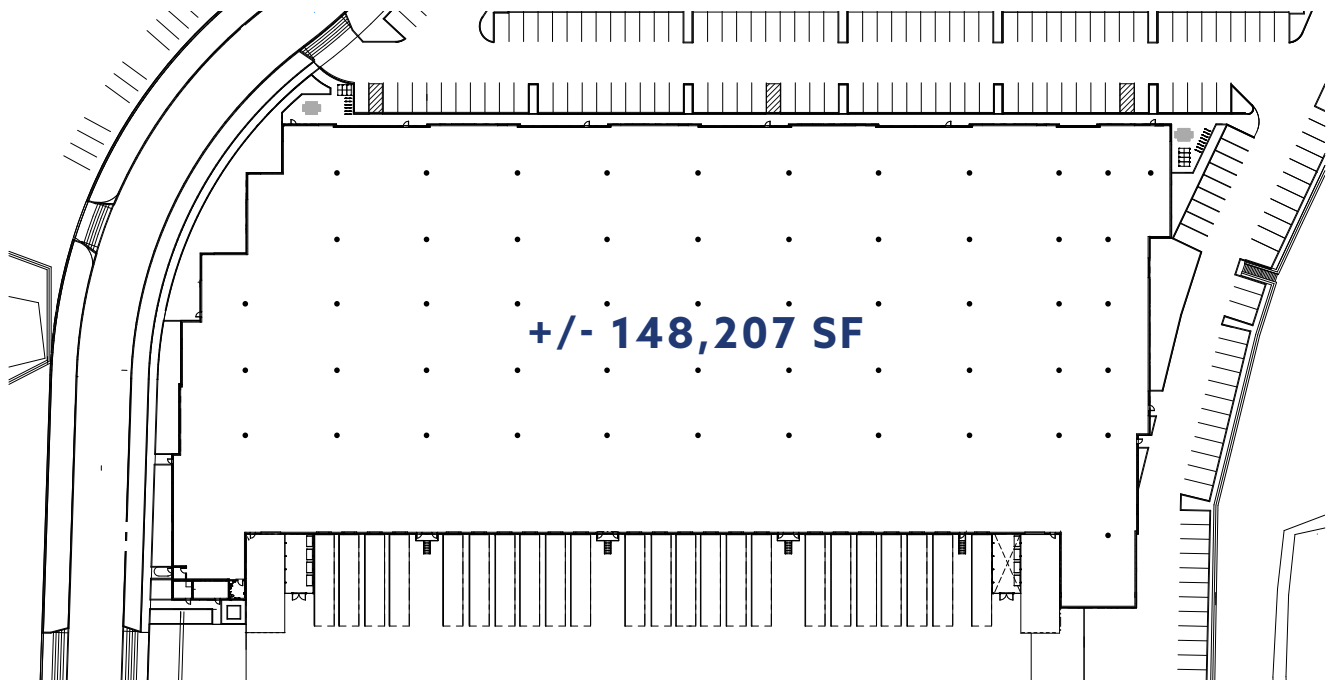
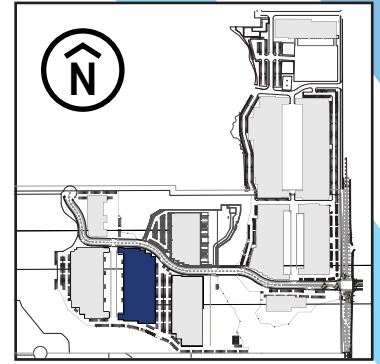

Building Size	+/- 148,207 square feet of ground floor area	Sprinkler System	ESFR sprinklers
Zoning	I-2	Column Grid	Typical 55' x 40' column spacing
Ceiling Height	36' clear ceiling height to structure	Power	3 - 400 amps services for 3 future tenants
Loading Doors	23 dock level doors with levellers 2 grade level doors	Heating	Gas fired unit heaters and fans
Floor Load	750 lbs. psf (live load)	Parking Stalls	+/- 153 stalls
Warehouse Lighting	LED to 30 foot candle		

BUILDING 7

30110 Blueridge Drive
FOR LEASE

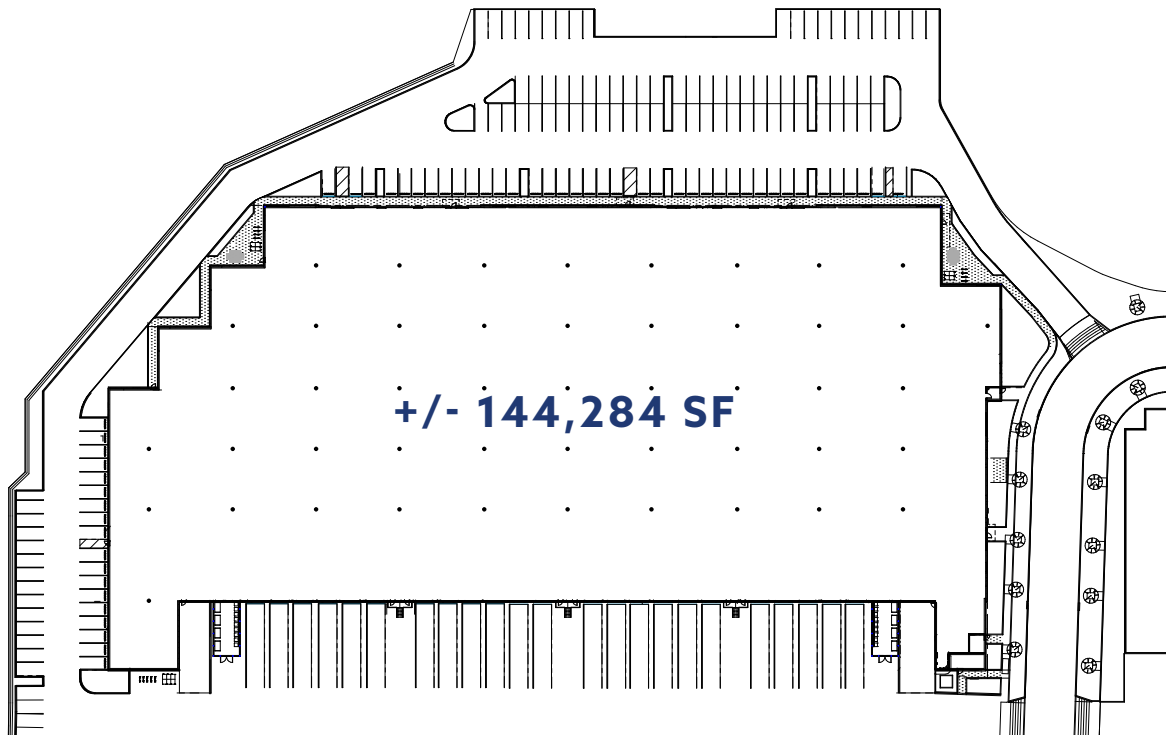
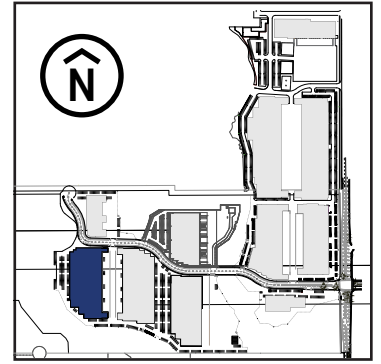

Building Size	+/- 144,284 square feet of ground floor area	Sprinkler System	ESFR sprinklers
Zoning	I-2	Column Grid	Typical 55' x 40' column spacing
Ceiling Height	36' clear ceiling height to structure	Power	3 - 400 amps services for 3 future tenants
Loading Doors	23 dock level doors with levellers 2 grade level doors	Heating	Gas fired unit heaters and fans
Floor Load	750 lbs. psf (live load)	Parking Stalls	+/- 148 stalls
Warehouse Lighting	LED to 30 foot candle		

BUILDING 8

FOR LEASE

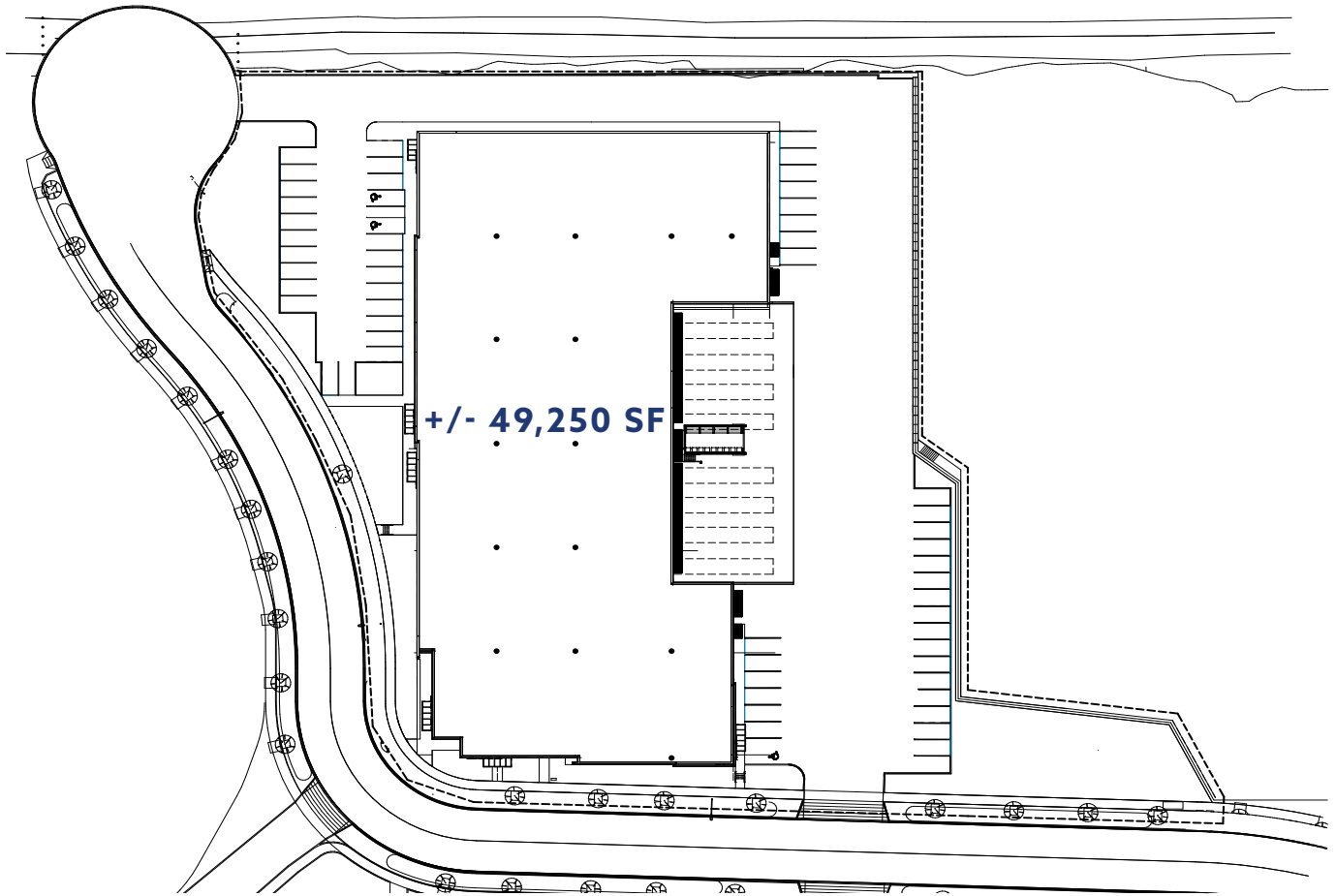
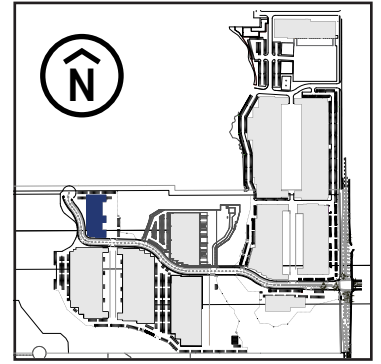

Building Size	+/- 49,250 square feet of ground floor area	Sprinkler System	ESFR sprinklers
Zoning	I-2	Column Grid	Typical 55' x 40' column spacing
Ceiling Height	32' clear ceiling height to structure	Power	Two 800 amp service - up to 2 tenants
Loading Doors	8 dock level doors with levellers 2 grade level doors	Heating	Gas fired unit heaters and fans
Floor Load	750 lbs. psf (live load)	Parking Stalls	+/- 53 stalls
Warehouse Lighting	LED to 30 foot candle		

BUILDING 11

FOR LEASE

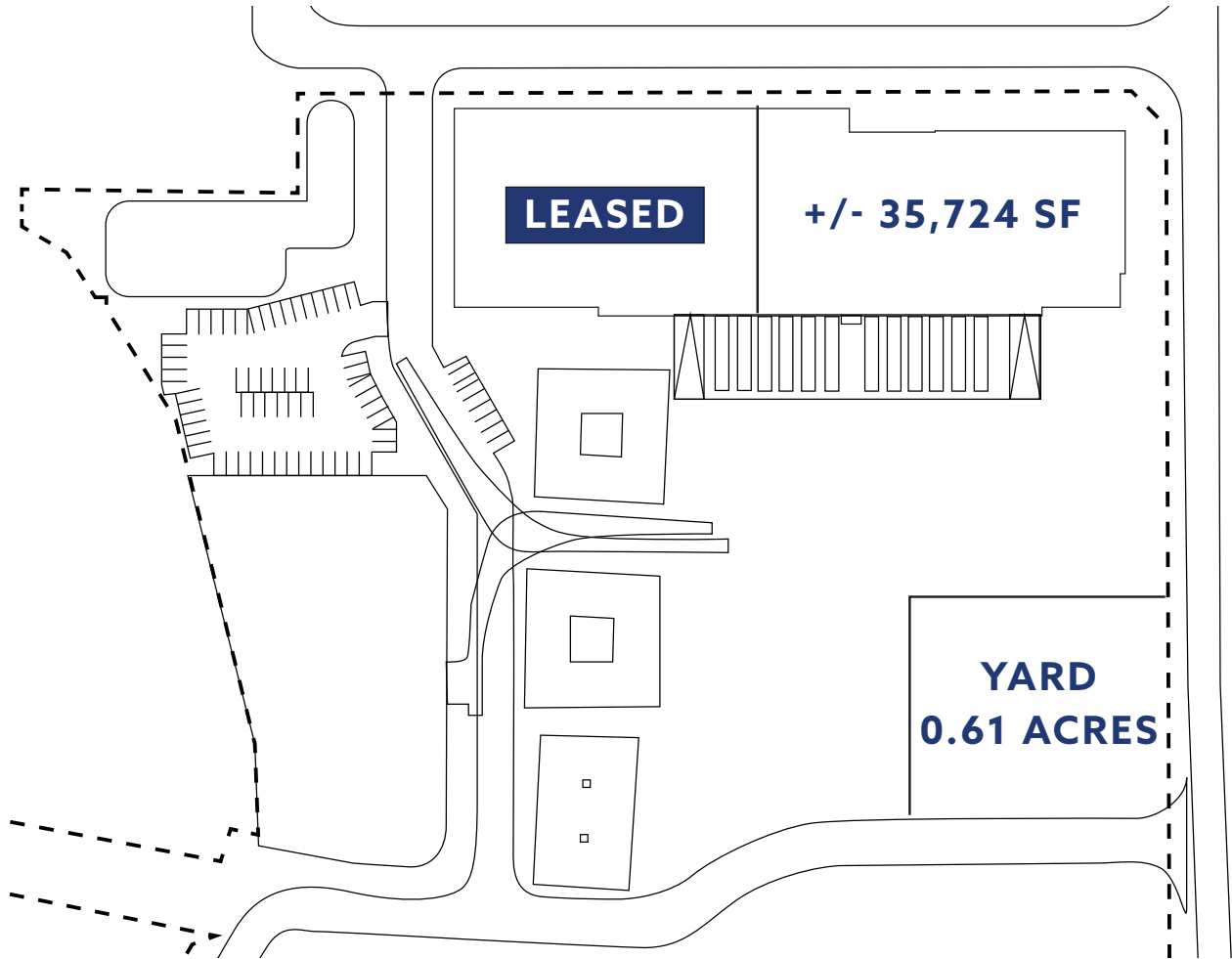
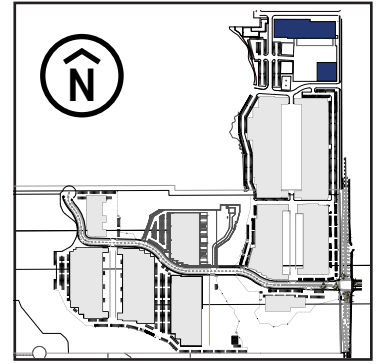

Building Size	+/- 71,000 square feet of ground floor area (additional mezzanine space can be added)	Sprinkler System	ESFR sprinklers
Zoning	I-2	Column Grid	55' column spacing
Ceiling Height	32' clear ceiling height with southernmost bay stepped down to +/- 20 square feet	Power	Maximum connected power 1,200 kva
Loading Doors	11 dock level doors with levellers 2 grade level doors	Heating	Gas fired unit heaters and fans
Floor Load	500 lbs. psf (live load)	Parking Stalls	+/- 95 stalls
Warehouse Lighting	LED to 30 foot candle	Yard Space	Up to 1.25 acres available adjacent to the building

PHASE 2

BUILDING DETAILS

BUILDING 9

FOR LEASE

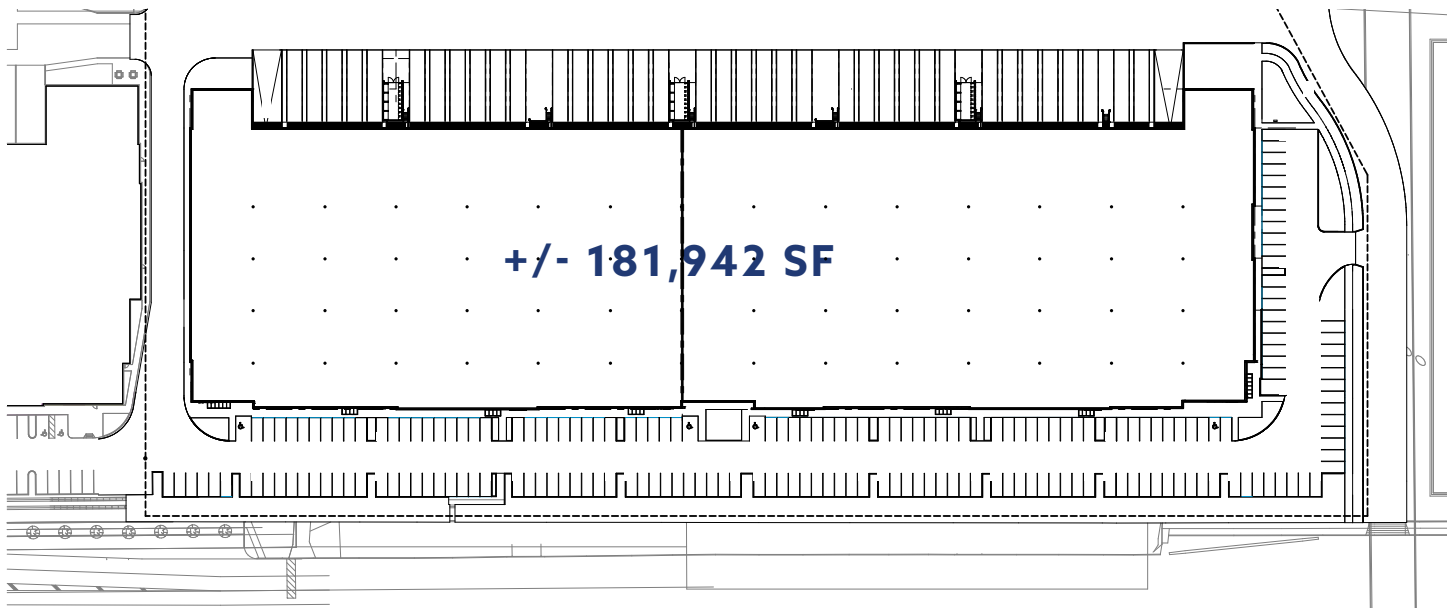
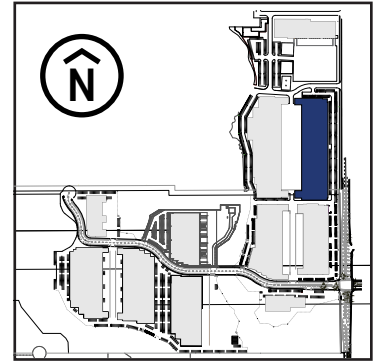

Building Size	+/- 181,942 square feet of ground floor area	Sprinkler System	ESFR sprinklers
Zoning	I-2	Column Grid	55' column spacing
Ceiling Height	36' clear ceiling height	Power	1600 amp 347/600-volt main distribution
Loading Doors	34 dock level doors with levellers 4 grade level doors	Heating	Gas fired unit heaters and fans
Floor Load	500 lbs. psf (live load)	Parking Stalls	TBC
Warehouse Lighting	LED to 30 foot candle		

BUILDING 10

FOR LEASE

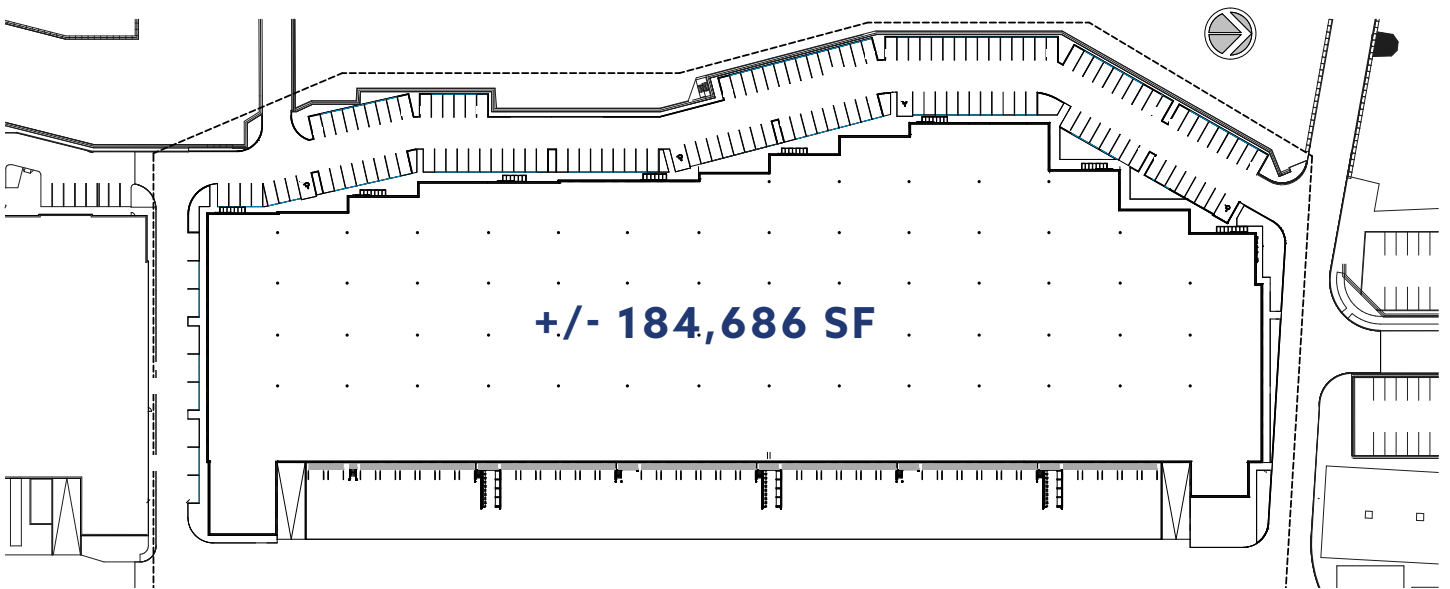
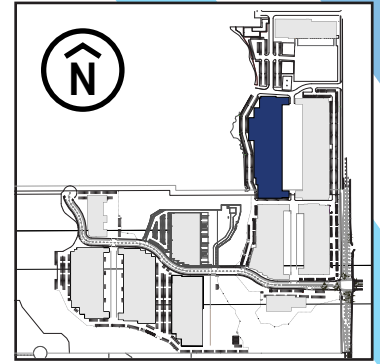

Building Size	+/- 184,686 square feet of ground floor area	Sprinkler System	ESFR sprinklers
Zoning	I-2	Column Grid	55' column spacing
Ceiling Height	36' clear ceiling height	Power	1600 amp 347/600-volt main distribution
Loading Doors	34 dock level doors with levellers 4 grade level doors	Heating	Gas fired unit heaters and fans
Floor Load	500 lbs. psf (live load)	Parking Stalls	TBC
Warehouse Lighting	LED to 30 foot candle		



YARD SPACE

DETAILS

YARD SPACE

FOR LEASE

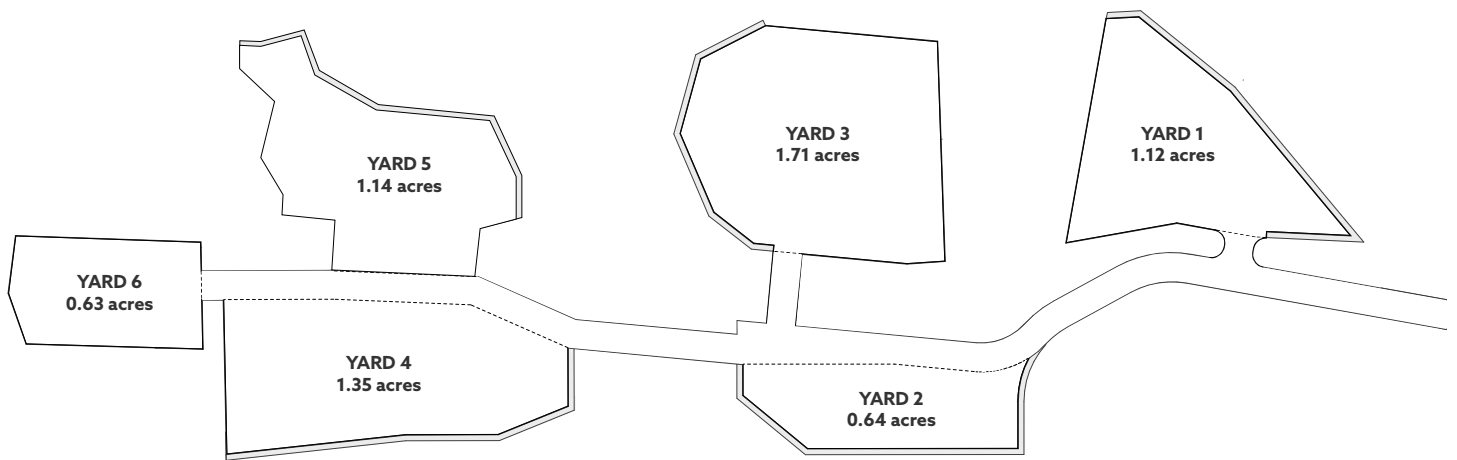
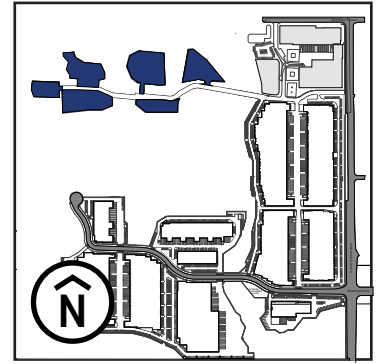

	Yard 1	Yard 2	Yard 3	Yard 4	Yard 5	Yard 6
Size	1.12 acres	0.6 acres	1.71 acres	1.35 acres	1.82 acres	0.63 acres
Zoning	I-2					
Yard Surface	Gravel					
Power & Water	Servicing such as power and water are flexible to the needs of the tenant					



XCHANGE BUSINESS PARK

Mount Lehman Road

Abbotsford, BC

xchangebusinesspark.com

JEFF RANK

Senior Vice President,

Leasing, Commercial, BC

604 975 9623

jeff.rank@quadreal.com

IRENE AU

Vice President,

Leasing, Commercial, BC

604 975 3586

irene.au@quadreal.com

XCHANGE
BUSINESS PARK AT MOUNT LEHMAN



Headquartered in Vancouver, British Columbia, QuadReal Property Group is a Canadian real estate investment, development and management company operating on a global scale. The company's \$24.5 billion portfolio spans 23 Global Cities across 17 countries. Owned by BCI, one of Canada's largest institutional investors, QuadReal was established to manage its real estate investment portfolio.

www.quadreal.com



Hungerford Properties is an institutionally-backed, award-winning real estate investment, management and development firm in Western Canada with over 50 years of experience building and refurbishing millions of square feet of commercial space. Hungerford has assembled a team of experts to bring this high-quality property to life, with a strong commitment to design, service and customer satisfaction.

www.hungerfordproperties.com

The Developer reserves the right to make modifications to floorplans, project design, materials and specifications to maintain the high standards of this development. E&OE